



Cambridge International Examinations
Cambridge International General Certificate of Secondary Education

CANDIDATE
NAME

--

CENTRE
NUMBER

--	--	--	--	--

CANDIDATE
NUMBER

--	--	--	--



DESIGN AND TECHNOLOGY

0445/42

Paper 4 Systems and Control

May/June 2015

1 hour

Candidates answer on the Question Paper.

No Additional Materials are required.

READ THESE INSTRUCTIONS FIRST

Write your Centre number, candidate number and name on all the work you hand in.

Write in dark blue or black pen.

You may use an HB pencil for any diagrams or graphs.

Do not use staples, paper clips, glue or correction fluid.

DO NOT WRITE IN ANY BARCODES.

You may use a calculator.

Section A

Answer **all** questions in this section.

Section B

Answer **one** question in this section.

At the end of the examination, fasten all your work securely together.

The number of marks is given in brackets [] at the end of each question or part question.

The total of the marks for this paper is 50.

This document consists of **17** printed pages and **3** blank pages.

Section A

Answer **all** questions in this section.

- 1 (a) Fig. 1 shows two sensing components with their circuit symbols. Name each component.

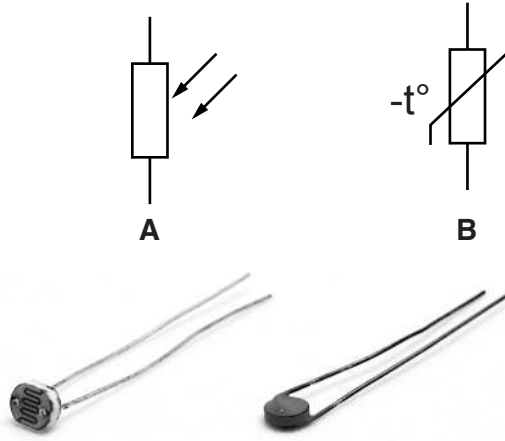

Fig. 1

A [1]

B [1]

- (b) Fig. 2 shows a resistance graph for sensor **A**.

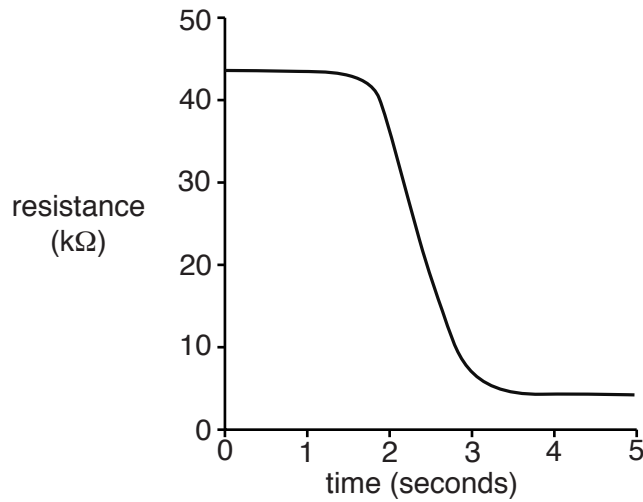

Fig. 2

Describe what has caused the change in resistance shown in the graph.

.....
.....
..... [2]

- 2 (a) Resistors can be connected in series to provide a precise value.
Circle the values from the list below that will give a resistance of 1.4 MΩ.

1 kΩ 680 kΩ 390 Ω 470 Ω 330 kΩ 680 Ω 390 kΩ [3]

- (b) In the space below draw **two** resistor symbols connected in series.

[1]

- 3 Plastics and plywood can both be used to make a casing for an electronic project.
Give **one** reason why plastics may be chosen rather than wood.

.....
..... [1]

- 4 Fig. 3 shows a can opener in the open position and in the closed position.
The two hand grips, **A** and **B** pivot about point **C** to bring the cutting wheel into contact with the can.

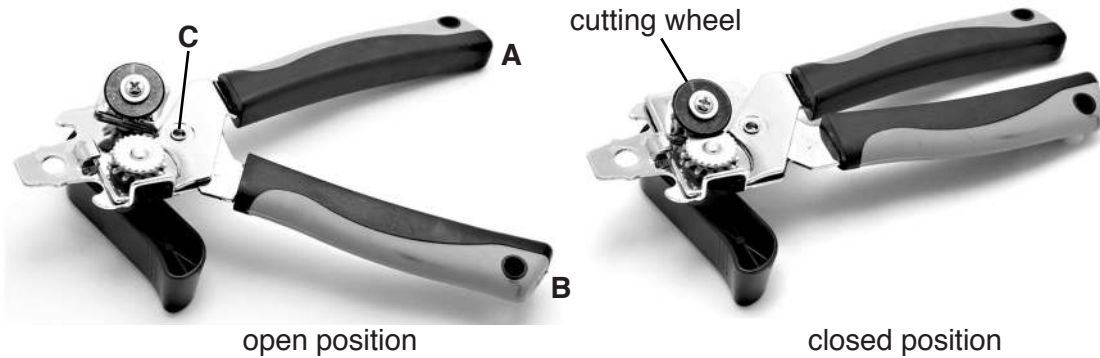

Fig. 3

- (a) State the order of lever used when the hand grips are closed to make the cutting wheel pierce a can.

..... [1]

- (b) Describe the type of motion that occurs when the hand grips are closed.

..... [1]

- (c) Draw force arrows on Fig. 3 to show where effort should be placed on grips **A** and **B** to apply the maximum load at the cutting wheel. [2]

- 5 Fig. 4 shows a close-up view of the can opener mechanism. Describe **two** effects of using gear wheels with the same number of teeth.



Fig. 4

- 1
- 2 [2]

- 6 Stored energy is often used for powering mechanisms. Give **two** examples of stored energy used in mechanisms.

- 1
- 2 [2]

- 7 Fig. 5 shows a reinforced concrete beam. Use notes and sketches to explain why the reinforcing rods are positioned as shown.

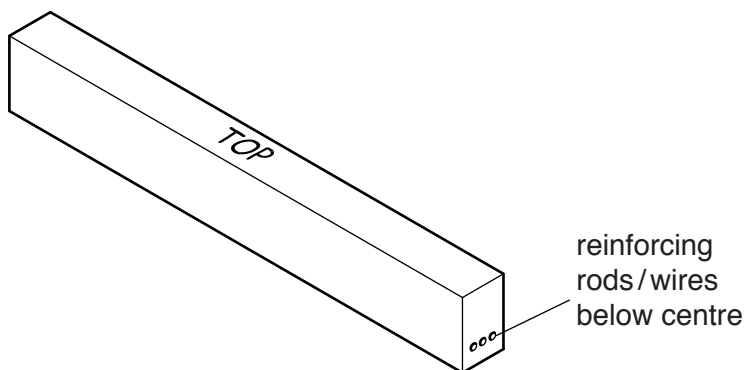

Fig. 5

[3]

8 Fig. 6 shows a roof truss made from softwood with a steel tie rod **A**.

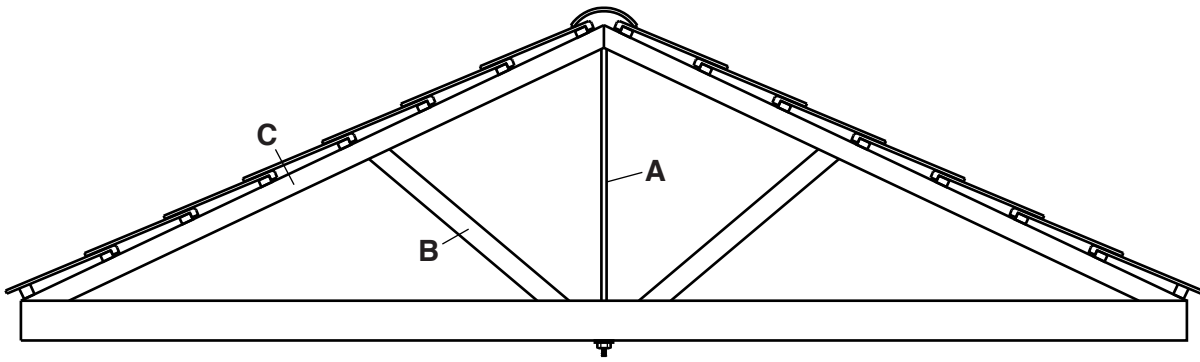

Fig. 6

Give the force that is acting at points **A**, **B** and **C**.

Force acting at point **A** [1]

Force acting at point **B** [1]

Force acting at point **C** [1]

9 Bicycle frames can be made using metals such as steel and aluminium, or from composite materials.

Give **two** advantages of using a composite material such as carbon fibre for a bicycle frame.

1

.....

2

..... [2]

Section B

Answer **one** question in this section.

- 10 (a) Fig. 7 shows the structure around a gas holder.

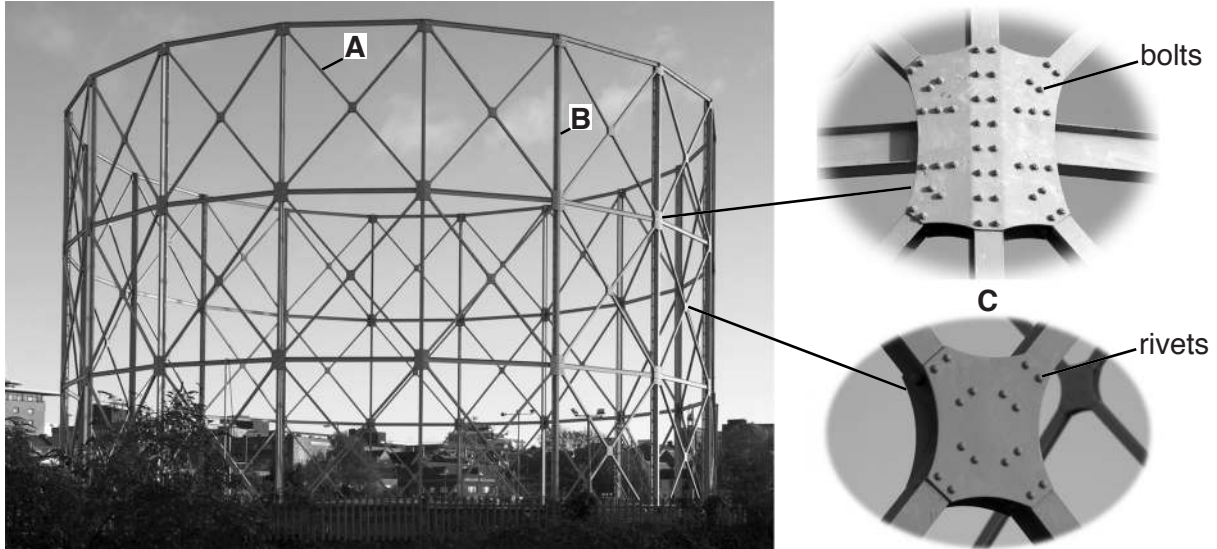
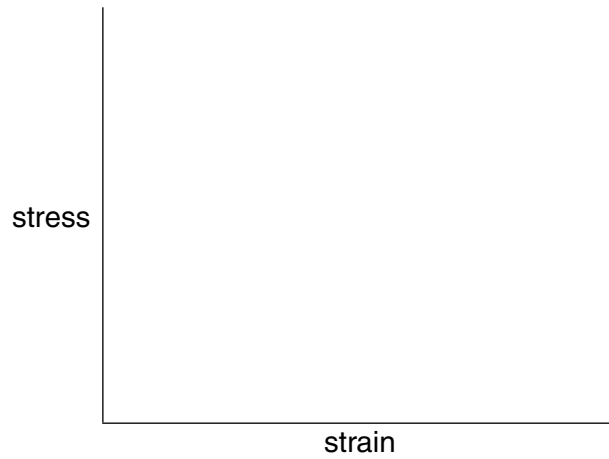

Fig. 7

- (i) State the type of structure shown in Fig. 7.
 [1]
- (ii) State the method used to keep the structure rigid.
 [1]
- (iii) Identify the structural elements labelled **A**, **B** and **C**.
A [1]
B [1]
C [1]
- (iv) The bolts and rivets used in the structure will be subject to shear force.
 Use notes and sketches to explain what happens when shear force is applied to a bolt or rivet that is holding two plates together.

[3]

(b) On the axes below draw a stress/strain graph for mild steel to show the elastic limit and upper yield point.



[3]

(c) (i) Fig. 8 shows a small crane lifting a 550 kg load.

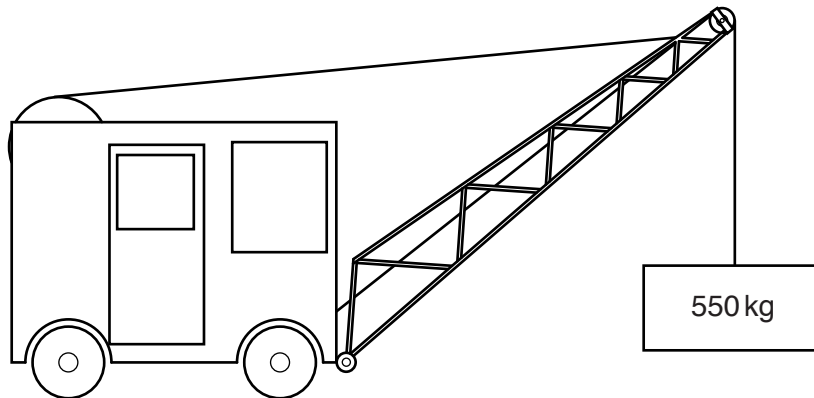

Fig. 8

The lifting cable used is 8 mm diameter.
Calculate the stress in the cable. 1 kg = 9.8 N

Use the formula $\text{stress} = \frac{\text{force}}{\text{cross sectional area}}$

.....

.....

.....

.....

..... [3]

- (ii) A 3 metre length of the steel cable extends by 1.2 mm with the load in place. Calculate the strain in the cable.

Use the formula **strain** = $\frac{\text{change in length}}{\text{original length}}$

.....

.....

..... [2]

- (d) A wooden beam that is part of the floor structure in a house has to be cut to allow heating pipes and power cables through. Fig. 9 shows three possible ways of making the cut.

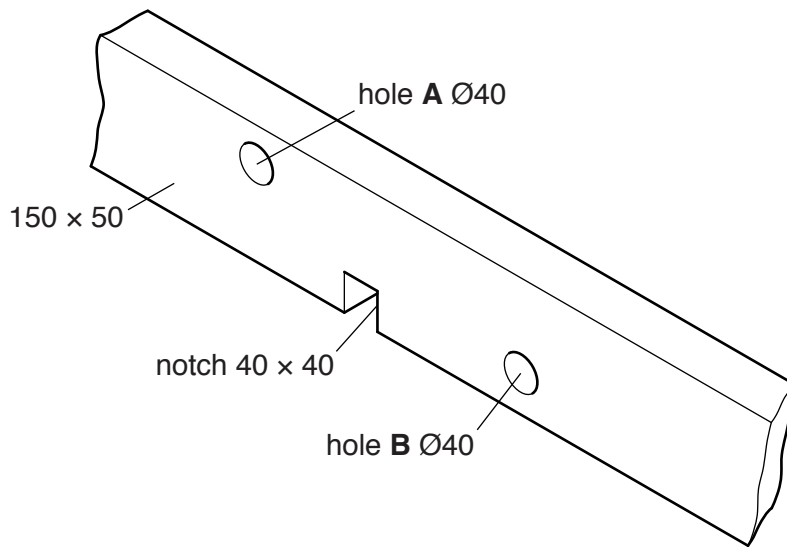

Fig. 9

- (i) State which method should be used to avoid weakening the beam.

..... [1]

- (ii) Explain your choice of method.

.....

.....

..... [3]

- (e) Fig. 10 shows an inspection cover that requires lifting. The downward force of the cover is 300 N, which is too much for one person to lift safely.

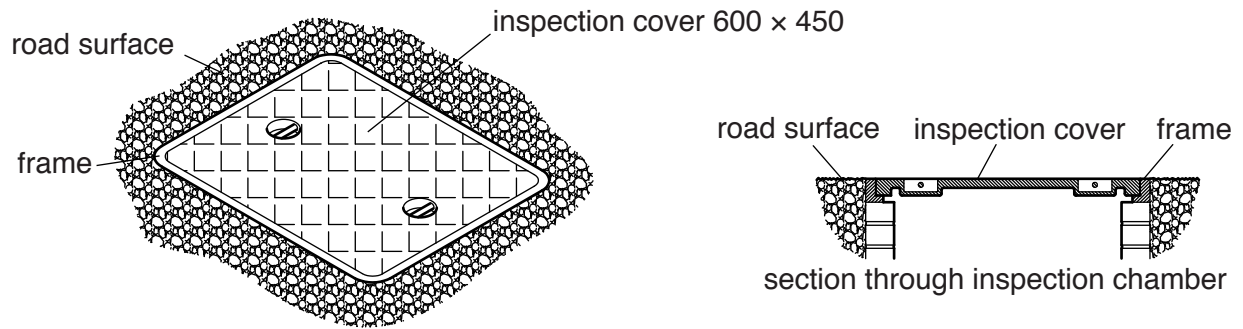

Fig. 10

Use notes and sketches to show a design for a lever system that will allow the cover to be lifted and replaced in the inspection hole.

The effort applied to the lever must be 100 N or less; include dimensions of the lever system and a calculation to show the effort required.

11 Fig. 11 shows a compass plane with an adjustable curved base used for producing interior and exterior curves on timber.



Fig. 11

(a) (i) Describe how the flexible steel base can be adjusted.

.....
 [2]

(ii) Indicate on Fig. 12 **two** points on the adjustment mechanism that should be lubricated.



Fig. 12

[2]

(iii) Name the most suitable type of lubrication to use.

..... [1]

(iv) Explain why lubrication of moving parts in a mechanism is important.

.....
..... [2]

(b) (i) Fig. 13 shows a single acting pneumatic cylinder and the symbol for the cylinder.



Fig. 13

Describe the operation of this type of cylinder.

.....
..... [2]

(ii) Describe **two** differences in operation between a single acting and double acting pneumatic cylinder.

.....
..... [2]

(c) (i) Name the cam shapes shown in Fig. 14.

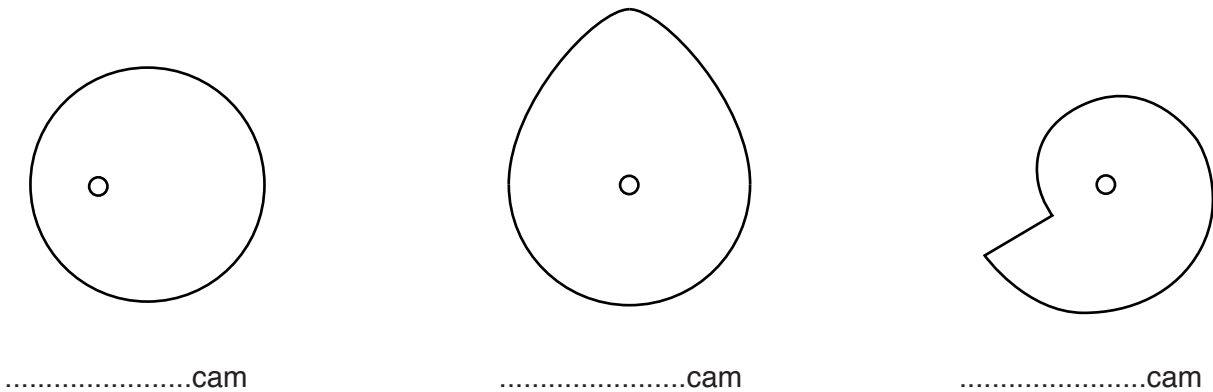

Fig. 14

[3]

(ii) Circle the cam that can only rotate in one direction.

[1]

(d) Fig. 15 shows details of a servo motor used to control model aircraft and boats.

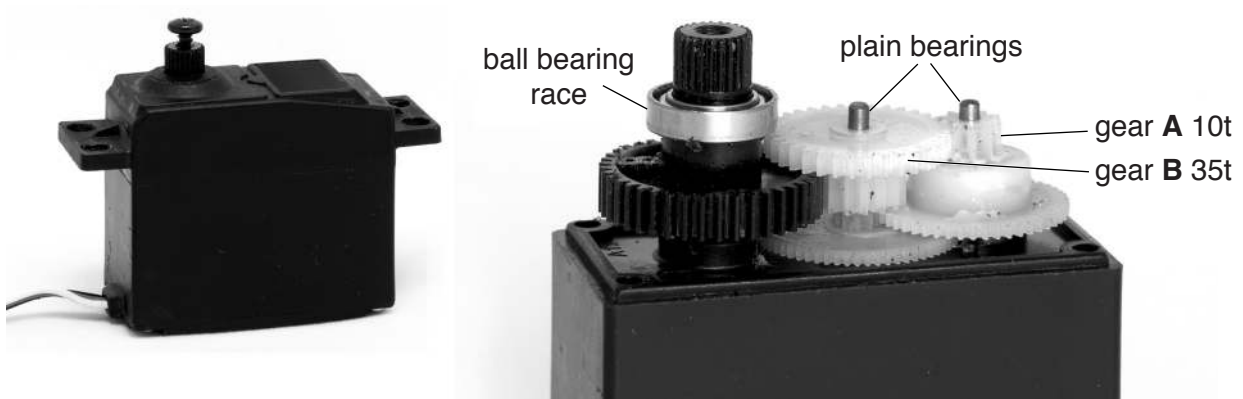

Fig. 15

(i) The nylon gears use plain bearings except for the final drive gear that has a ball bearing race.
Give **two** advantages of using a ball bearing race rather than a plain bearing.

1

2 [2]

(ii) The servo motor uses a compound gear train to reduce the speed at the output shaft.
Describe the features of a compound gear train.

.....

 [3]

(iii) Gear **A** in Fig. 15 drives gear **B**.
Calculate the speed of gear **B** when gear **A** rotates at 462 rpm.

.....

 [2]

(e) Fig. 16 shows an electric motor connected to a compressor by a vee belt.

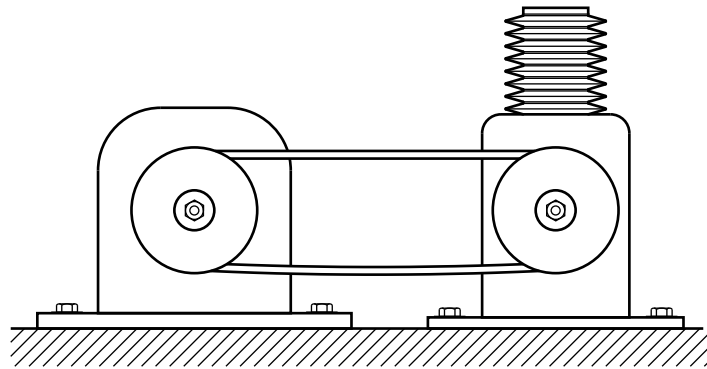

Fig. 16

Use notes and sketches to show **one** method of adjusting the tension on the vee belt.

[3]

- 12 (a) (i) Solder used in constructing electronic circuits is normally lead free.
Give **one** reason for using lead free solder rather than solder containing lead.
..... [1]
- (ii) Multicore solder contains flux.
Describe the purpose of flux when soldering.
.....
..... [2]
- (iii) State **two** risks to the operator when soldering.
1
2 [2]
- (iv) Describe the precautions that can be taken to ensure the safety of an operator when soldering.
.....
..... [2]

(b) A common cathode seven segment display is shown in Fig. 17.

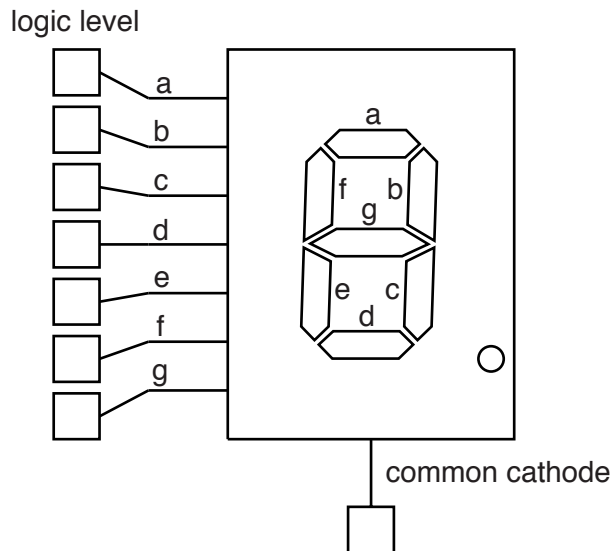

Fig. 17

- (i) Give the meaning of the term 'common cathode'.
..... [1]
- (ii) Write a '0' or a '1' in each of the input boxes in Fig. 17 to show the logic level of each input when the display shows 5. [4]

- (iii) Fig. 18 shows a 4026 CMOS counter IC symbol with each output connected through a resistor to a segment of the display.

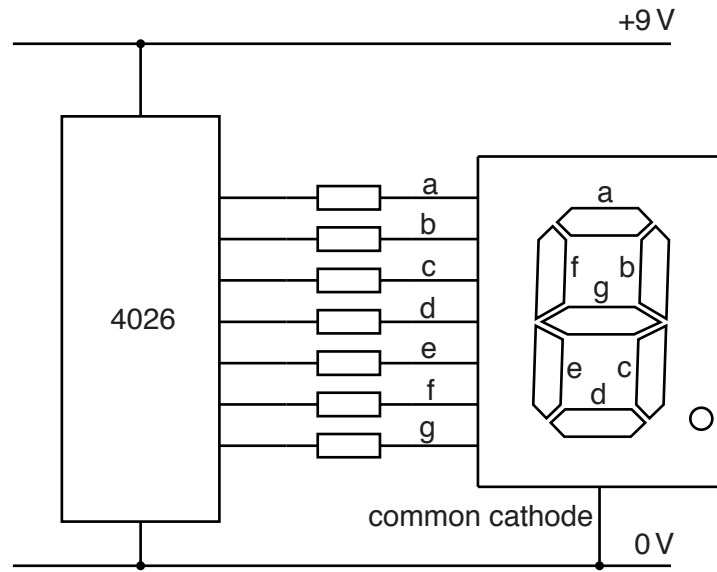

Fig. 18

Calculate the value of resistor needed to limit the current in a segment to 15 mA. There is a voltage drop of 2V on each segment of the display.

Use the formula $V = I \times R$

.....

.....

.....

..... [3]

- (iv) The seven resistors needed for the display are available either as separate resistors or as a dual in line (DIL) package as shown in Fig. 19.

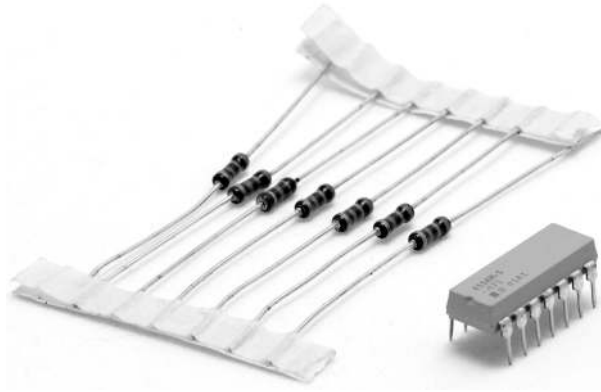

Fig. 19

Give **one** benefit of using the DIL package and **one** benefit of using separate resistors.

Benefit of DIL package [1]

Benefit of separate resistors [1]

- (c) Fig. 20 shows part of the printed circuit layout and the pin diagram for the 4026 IC.

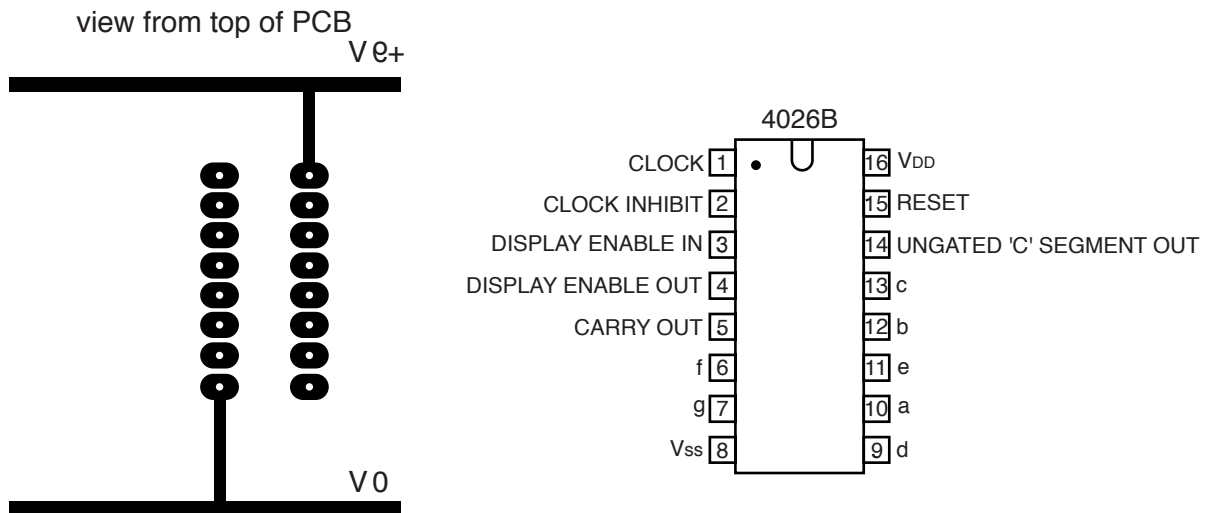

Fig. 20

Add tracks to make the following connections:

- DISPLAY ENABLE IN (pin 3) to +9V
- CLOCK INHIBIT (pin 2) to 0V.

[2]

- (d) When the 4026 IC is counting, the reset pin (15) is connected to 0V. To reset the count to zero the reset pin is connected to +9V. Fig. 21 shows the components used to operate the reset. Add connections from R1 and SW1 to allow the count to take place and then to be reset.

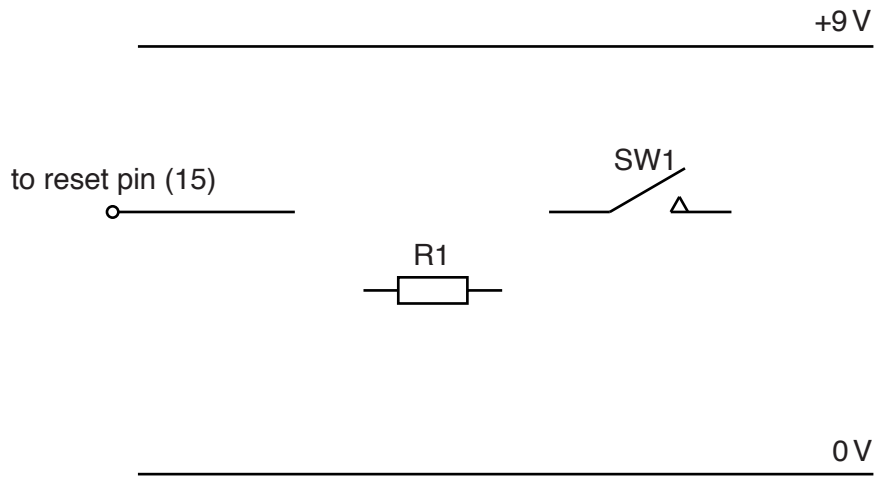

Fig. 21

[3]

- (e) (i) An astable signal can be used as the input to a counter IC. Use notes and sketches to describe an astable signal.

[2]

- (ii) Name an IC that can provide an astable signal.

..... [1]

BLANK PAGE

Permission to reproduce items where third-party owned material protected by copyright is included has been sought and cleared where possible. Every reasonable effort has been made by the publisher (UCLES) to trace copyright holders, but if any items requiring clearance have unwittingly been included, the publisher will be pleased to make amends at the earliest possible opportunity.

To avoid the issue of disclosure of answer-related information to candidates, all copyright acknowledgements are reproduced online in the Cambridge International Examinations Copyright Acknowledgements Booklet. This is produced for each series of examinations and is freely available to download at www.cie.org.uk after the live examination series.

Cambridge International Examinations is part of the Cambridge Assessment Group. Cambridge Assessment is the brand name of University of Cambridge Local Examinations Syndicate (UCLES), which is itself a department of the University of Cambridge.